

# FG series

## FIXED GRIP™ hand controllers

Distinctive features and specifications



- USB outputs available
- Rugged hand operation
- Sealed up to IP67
- Custom configured

### ENVIRONMENTAL

- Operating Temperature: -25°C to 70°C (-13°F to 158°F)
- Storage Temperature: -40°C to 70°C (-40°F to 158°F)
- Sealing: IP67
- EMC Immunity Level (V/M): IEC 61000-4-8:2009
- EMC Emissions Level: IEC 61000-4-3:2006
- ESD: IEC 61000-4-2:2008

NOTE: All values are nominal

### STANDARD SWITCH CHARACTERISTICS/RATINGS

- Electrical Resistive Load: 5A (depending on the chosen switch)
- Electrical Inductive Load: 3A (depending on the chosen switch)
- Low Level: 10mA @ 30mV (depending on the chosen switch)
- Electrical Life: 1 million cycles 5A @ 28 VDC resistive snap-action (depending on the chosen switch)
- Mechanical Life: 1,000,000 cycles
- Environmental Seal: IP67
- Action: Momentary, snap-action
- Operating Force: 7.5N±2.0N (1.69lbf±0.11lb)
- Total Travel: 0.080 inch max
- Over Travel: 0.010 inch min

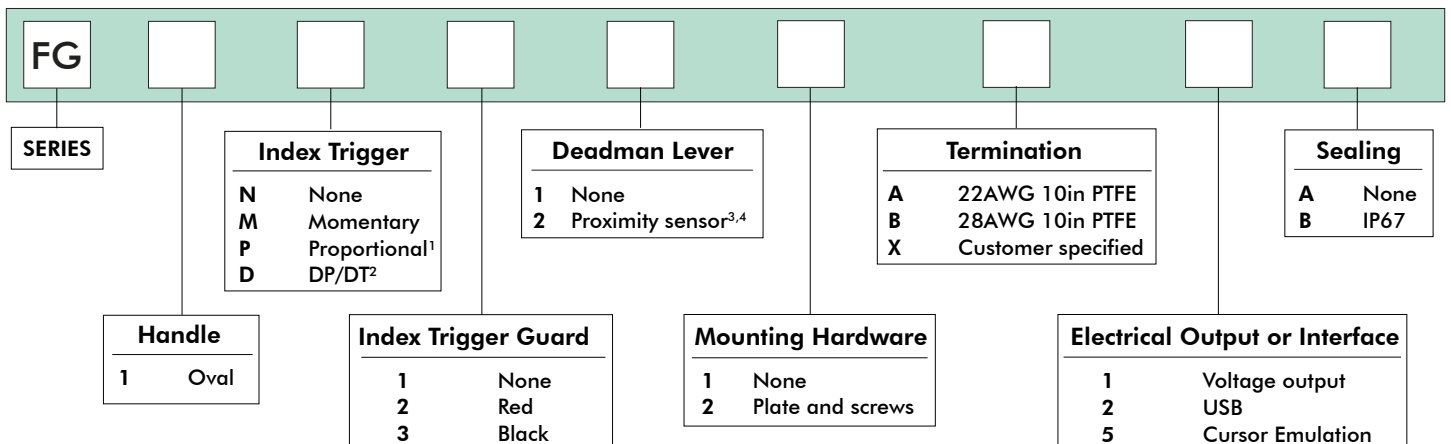

#### NOTES:

- 1 0.5V to 4.5V output.
- 2 Double pole/double throw.
- 3 Not available with trigger.
- 4 The proximity sensor used in this joystick is based on an auto calibrating integrated circuit. The circuit automatically calibrates itself, when the device is not activated to maintain the sensitivity of the proximity sensor to within specification. Due to this auto calibrating feature there may be a slight delay in the sensor between subsequent engagements of the joystick. If the proximity sensor fails to activate, disengaging the joystick for 30 seconds, will reset the proximity sensing calibration system. APEM's joystick proximity sensor option is offered for operator convenience and should not be used as a safety device. It is the customer's responsibility to provide backup safety measures.



Up to IP67 available.



Mounting accessories. Screws: 1/4-20 x 1.25in stainless steel screws, lock washers, and hex nuts.

Note: The company reserves the right to change specifications without notice.

# FG series

## FIXED GRIP™ hand controllers

### Overview

#### HANDLE / INDEX TRIGGER

##### INDEX TRIGGER WITH TRIGGER GUARD



##### INDEX TRIGGER



##### NO INDEX TRIGGER

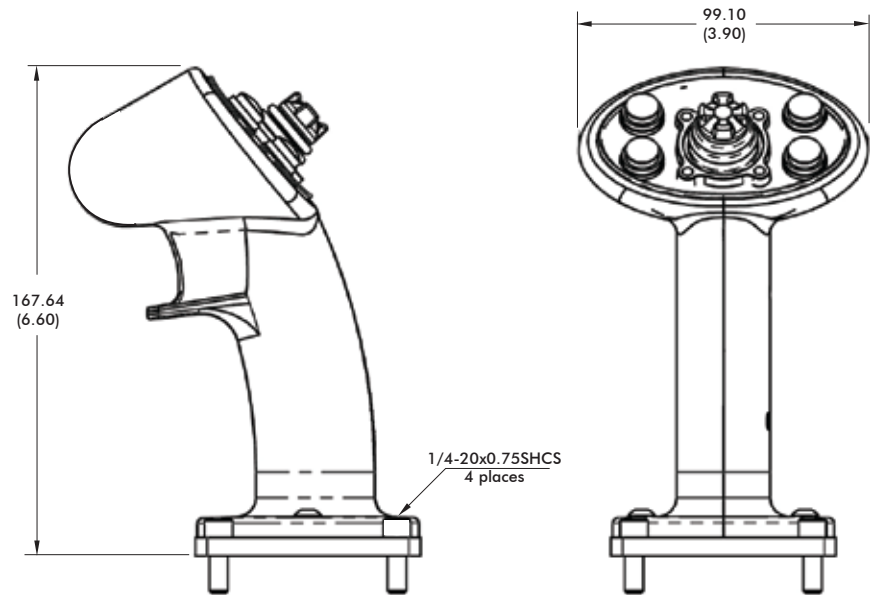

#### NOTES

1. Dimensions are in mm/(inch).

#### 2. FACEPLATE:

The FG series FIXED GRIP hand controller features a modular faceplate that can be customized for specific applications.

Ambidextrous for most configurations, the faceplate may be populated with a variety of thumb actuated switches including momentary pushbuttons, latching pushbuttons, two or three way toggle switches, 4 or 5 way trims, and miniature proportional joysticks. Every FG faceplate is custom configured to order. Please consult factory for options.

#### 3. INDEX TRIGGER

The FG series FIXED GRIP controllers may be equipped with or without an index trigger switch. Index trigger configuration options include a single pole normally open momentary switch, a double pole double throw tactile switch, or a proportional Hall effect device.

Index Trigger Options: N: None

M: Momentary, single pole normally open

P: Hall effect, 0.5V to 4.5V proportional output

D: Double pole, double throw

#### 4. DEADMAN LEVER

The Proximity Sensor is a person present "deadman" safety switch that works by means of capacitive sensing. Fitted inside the handle and sealed from the environment, the Proximity Sensor eliminates the need for a mechanical paddle lever.

Deadman Lever Options: 1: None

2: Proximity Sensor

Note: The company reserves the right to change specifications without notice.

# FG series

## FIXED GRIP™ hand controllers

Overview

### USB

#### USB

Featuring USB 1.1 HID compliant interface, APEM's USB joysticks are recognized as standard HID "game controller" devices. Adhering to the HID specification, APEM's USB joysticks are plug-and-play with most versions of Windows. Joystick button and axis assignments are dependent upon the controlled application.

#### FEATURES

- USB 1.1 HID compliant "game controller" device
- Easy to install and operate
- Functions determined by controlled application

#### SUPPLIED WIRING

USB: USB Male Type A Connector with overmolded cable

#### CURSOR EMULATION

The Cursor Emulation option converts multi-axis joystick output into a mouse, trackball, or cursor control device. The joystick's internal microprocessor converts absolute axis position into a cursor velocity, which is translated as a relative trackball or mouse position.

#### APPLICATIONS

The Cursor Emulation option is ideal for vehicle applications subjected to dirt and high vibration which makes operating a traditional cursor control device difficult. The Cursor Emulation option is widely used in shipboard and military applications.

#### FEATURES

- HID compliant "pointing device"
- Plug-and-play with USB option

#### SUPPLIED WIRING

USB: USB Male Type A Connector with overmolded cable